

Banseok Precision Industry Co., Ltd.

ENGLISH

PRODUCT CATALOG

THE WORLD'S NEW INTRODUCTION OF THE DISPENSING TECHNOLOGY

PRECISION DISPENSING



www.banseok.co.kr



CONTENTS

- 06 SYSTEM
- 12 CONTROLLERS
- 20 DISPENSING VALVES
- 32 PRESSURE TANKS
- 36 PRESSURE PUMPS
- 40 DISPENSING PUMPS
- 44 GEAR PUMP COMPOUND UNITS
- 46 ROBOTS
- 56 ACCESSORIES
- 71 APPLICATIONS



BANSEOK
PRECISION
INDUSTRY CO., LTD.

1996 Founded in

Banseok Precision Industry has a differentiated production system based on technology and know-how accumulated over 25 years.



Enter more than **20** countries around the world

Banseok is recognized for our global competitiveness, supplying equipment to more than 20 countries around the world, including USA, Germany, Japan, and France.

Partnership with **5,200** domestic companies

Banseok provides the best dispenser equipment to the top domestic companies, including Samsung Electronics, Hyundai Mobis, LG Innotek, Hanwha Q-Cell, etc.

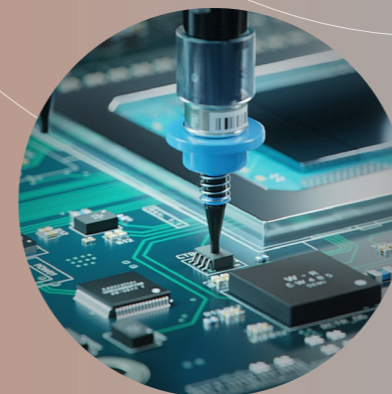

ONE-STOP customizing system

Banseok offers the best solution for customer needs, from customer consultation to equipment design, testing, and after services.

CUSTOMIZING SUPPORT FOR CUSTOMERS

The dispensing system requires professional Know-How to be applied to the application. Different equipment and system should be applied based on the application field, used material, and dispensing accuracy. Banseok supports customers to customize the system depending on the specifications of the customer's need with Banseok's Know-How.

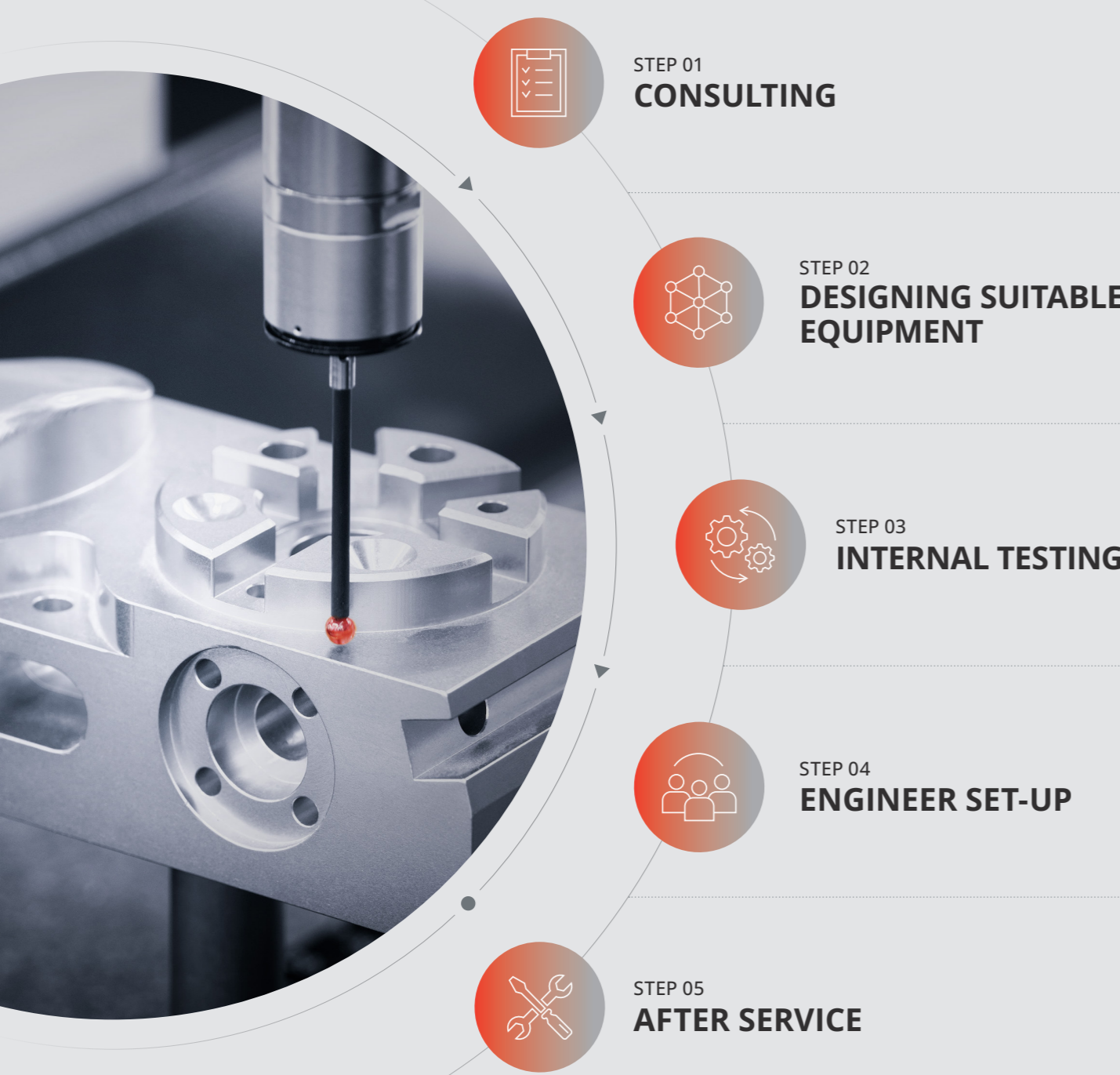

CONCEPT OF VISCOSITY

Dispensing technology applies different controlling methods depending on the material's chemical properties, fluidity, and curing conditions. Therefore, we need to understand the viscosity, dispensing volume, shape, and operation method to use a suitable system for the application. Viscosity particularly can be anticipated referring to the fluid material around us.

Viscosity Graph

The units of viscosity shown in the fluid property table can be converted as below.

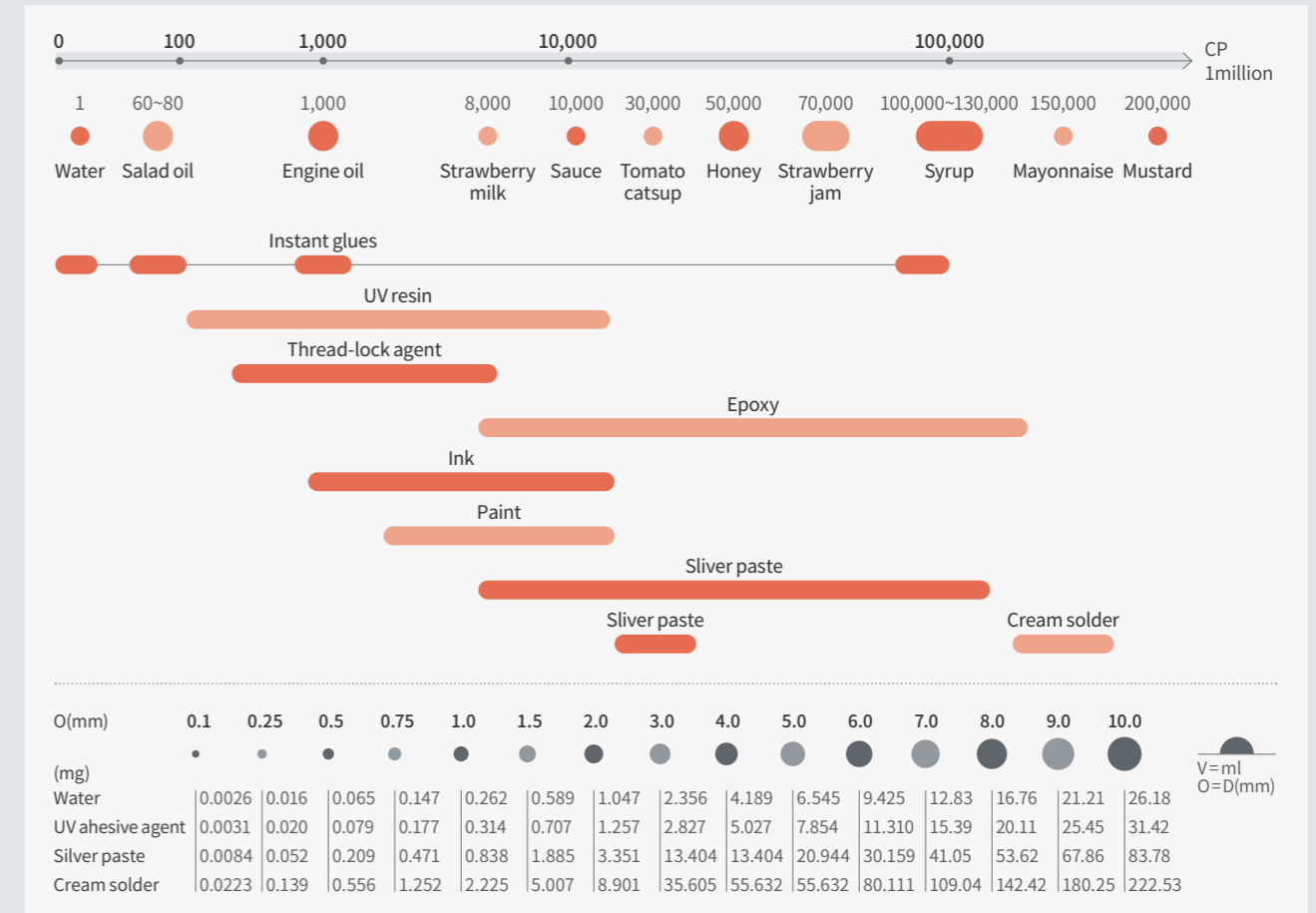

Viscosity Unit Chart

| unit | cP | P(g/cm.s) | gmf.s/cm ² | lbf.s/in ² | mPa-s | N.s/m ² |
|-----------------------|---------|-----------|-----------------------|-----------------------|---------|--------------------|
| cP | 1 | 0.01 | 1.02e-7 | 1.45e-7 | 1 | 0.001 |
| P(g/cm.s) | 100 | 1 | 1.02e-6 | 1.45e-5 | 100 | 0.1 |
| gmf.s/cm ² | 98039.2 | 980.392 | 1 | 0.014219 | 98039.2 | 98.0392 |
| lbf.s/in ² | 6894757 | 68947.57 | 70.3265 | 1 | 6894757 | 6894.76 |
| mPa-s | 1 | 0.01 | 1.02e-7 | 1.45e-7 | 1 | 0.001 |
| N.s/m ² | 1000 | 10 | 0.0102 | 1.45e-7 | 1000 | 1 |

Pot Life

- Pot life is a period in which viscosity changes little generally for 100g material, so it is possible to work at a room temperature of 25°C.
- The time it takes to reach twice the initial viscosity, and after this time, the curing accelerates rapidly.

Hardening conditions

- Fluids curing conditions can be natural curing, thermal curing, chemical reaction curing, UV curing, and moisture curing. The dispensing equipments can be chosen after checking these properties.



Dispensing Unit

The unit dispenses the fluid directly to the product. Various types can be selected depending on the dispensed volume, fluid viscosity, specific gravity, and dispensing accuracy.



Controller

The unit controls the operation of the dispensing unit or supplying unit. The controller regulates the dispensing time, volume, and other functions.



Supplying Unit

The unit supplies the fluid material to the dispensing unit. It includes barrel, cartridge, tank, and pressure pumps, that can be chosen regarding the fluid viscosity, specific gravity, and presence of the filler.

SYSTEM

The essential components of the fluid dispensing system include a fluid supplying unit, a controller, and a fluid dispensing unit. With Banseok's standard systems, you can choose the suitable equipments according to the fluid property and application purpose.

TAD-101 SYSTEM



The basic system using controller which regulates the air pressure, and the barrel which is connected directly to the controller. The dispensed amount can be adjusted by given input time, air pressure and the needle size.



Applicable Controller



TAD-200S



TAD-300L



TAD-280L

TAD-102 SYSTEM



Similar to TAD-101, the system dispenses larger amount of fluid using cartridge or cartridge type material placed in cartridge holder.



TAD-103 SYSTEM



Applicable Controller



TAD-200S



TAD-300L



TAD-280L

The system dispenses materials in the barrel or the cartridge using dispensing valve to meet high accuracy and to remove fluid dripping due to a remaining pressure after dispensing.



TAD-104 SYSTEM



The system dispenses materials in the pressure tank, using dispensing valve and controller. This system holds a large amount of material, therefore suitable for an application dispensing a large amount at a time or frequently filling the container.

TAD-105 SYSTEM



The system dispenses fluid materials of high viscosity using pressure pump.

Can-type fluid material goes directly to the pressure pump and controlled by the valve and the controller.



CONTROLLER

DISPENSING CONTROLLER

TAD-200S

Single action type controller

Controller for barrel, cartridge, and single action type valve.

This single action type controller has convenience functions for users including interval timer, vacuum control, digital timer, and memorizing function, etc.

- * Interval Timer – Functions including automatic dispensing, automatic stop, etc are available by setting time.
- * Vacuum Control – Dripping phenomenon of low-viscosity fluid after dispensing can be prevented using vacuum control function.
- * Digital Timer – The digital timer displayed on LED in manual mode.
- * Memorizing function – Memorizes the values for dispensing until setting values again.



TAD-200V

Double action type controller

This controller has the same function as TAD-200S and is suitable for double action type valves.



| Model | TAD-200S |
|-----------------------------|--|
| Control Method | Electronic / Pneumatic System |
| Dispensing pressure | 0~10kg/cm ² (S: Standard) 0~4kg/cm ² (L: Option) 0~2kg/cm ² (P: Option) |
| Time Range | 0.01~99.99 sec |
| Interval Timer | 0.01~99.99 sec |
| Vacuum Pressure | 0~ -350mmHg |
| Out Signal | Open connector, DC 24V 20mmsec (Relay), 100mmsec (Relay) |
| Power Source | AC220C 50/60Hz (AC100V 50/60Hz: Option) |
| Power Consumption | 32W |
| External Dimension & weight | 232(W) x 186(D) x 81(H)mm, 2.7kg |

| Model | TAD-200V |
|-----------------------------|--|
| Control Method | Electronic / Pneumatic System |
| Dispensing pressure | 0~10kg/cm ² (S: Standard) 0~4kg/cm ² (L: Option) 0~2kg/cm ² (P: Option) |
| Time Range | 0.01~99.99 sec |
| Interval Timer | 0.01~99.99 sec |
| Out Signal | Open connector, DC 24V 20mmsec (Relay), 100mmsec (Relay) |
| Power Source | AC220C 50/60Hz (AC100V 50/60Hz: Option) |
| Power Consumption | 32W |
| External Dimension & weight | 232(W) x 186(D) x 81(H)mm, 2.7kg |

CONTROLLER

DISPENSING CONTROLLER

TAD-280L

High quality version of TAD-200S

This high quality version of TAD-200S has reduced error rate from previous 20% to 3%, and 50% improved dispensing reaction time, a more precise time setting function of 0.001sec, and little noise due to high quality silencer.



| Model | TAD-280L |
|-----------------------------|--|
| Control Method | Electronic / Pneumatic System |
| Dispensing pressure | 0~10kg/cm ² (S: Standard) 0~4kg/cm ² (L: Option) 0~2kg/cm ² (P: Option) |
| Time Range | 0.01~99.99 sec |
| Pattern Channel | 1~10 Channels |
| Memory Fuction | 500 memories |
| Display Section | LCD digital display |
| Input / Output Signal | Open connector, DC 24V |
| Out Signal | Open Collector, DC 24V |
| Power Source | AC220C 50/60Hz (AC100V 50/60Hz:Option) |
| External Dimension & weight | 176(W) x 154(D) x 72(H)mm, 2.4kg |

| Model | TAD-300L |
|-----------------------------|--|
| Control Method | Electronic / Pneumatic System |
| Dispensing pressure | 0~10kg/cm ² (S: Standard) 0~4kg/cm ² (L: Option) 0~2kg/cm ² (P: Option) |
| Time Range | 0.01~99.99 sec |
| Vacuum Pressure | 0~ -350mmHg |
| Out Signal | Open connector, DC 24V |
| Power Source | AC220C 50/60Hz (AC100V 50/60Hz:Option) |
| Power Consumption | 6W |
| External Dimension & weight | 176(W) x 154(D) x 72(H)mm, 2.4kg |



TAD-300L

Time calibration type controller

This controller has the same function as TAD-280L, but improved time calibration function to 0.001sec. TAD-300L enables the digital time setting, thus more accurate time setting with LCD Digital Display is possible.



CONTROLLER

VACUUM PICK-UP CONTROLLING DISPENSER

TAD-200SP

Vacuum pick-up controller

This controller has the same function as TAD-200S and added vacuum system for Pick-Up pen. It makes easy assembly of small components and repairing/reworking using its own pick-up pen: MN-5. The vacuum rate can be controlled according to the product size&weight.



| Model | TAD-200SP |
|-----------------------------|---|
| Control Method | Electronic / Pneumatic System |
| Time Range | 0.01~99.99 sec |
| Interval Timer | 0.01~99.99 sec |
| Vacuum Pressure | 0~ -350mmHg |
| Out Signal | Open connector, DC 24V 20mmsec(Relay) |
| Power Source | AC220C 50/60Hz (AC100V 50/60Hz:Option) |
| Power Consumption | 32W |
| External Dimension & weight | 282(W) x 186(D) x 81(H)mm, 3.0kg |



SPRAY VALVE CONTROLLER

TAD-500SR

Conformal coating valve controller

This controller regulates the air blow and fluid dispensing of the conformal coating valve. With the introduction of precise regulator, 0.001MPa can be adjusted. The digital display and simple interface enables convenient&precise setting.



| Model | TAD-500SR |
|-----------------------------|-------------------------------------|
| Control Method | Electronic / Pneumatic System |
| Time Range | 5bar/20ms |
| Interval Timer | 0.01~99.99 sec |
| Out Signal | DC24V, 2.5A |
| Power Source | 220V, 1A, 50/60Hz |
| External Dimension & weight | 260(W) x 135(D) x 95(H)mm, 3.0kg |



CONTROLLER

HEATER CONTROLLER

EZ TEM-3

Heating Controller

This controller provides the heating solution that makes fluid viscosity appropriate to be dispensed.



| Model | EZ TEM-3 |
|-----------------------------|---|
| Indication Accuracy | ±0.3% of indication value or ±3°C, whichever is greater |
| Control Method | ON/OFF or P,PI,PD,PIDF,PIDS |
| Indication Method | 7Segment LED display [PV: RED, SV: GREEN] |
| Control Sensitivity | 1~100(0.1~100.0)°C Variable, when using ON/OFF control |
| Temperature Range | Low-Temperature: Room temperature~80°C/ High-Temperature: Room temperature~200°C |
| Power Source | AC110-240C 50/60Hz |
| External Dimension & Weight | 121(W) x 150(D) x 65(H)mm |

PROGRESSIVE CAVITY PUMP CONTROLLER

BP-2

Progressive Cavity Pump Controller

A BPP-Series controller which controls the motor connected to the Rotor. It controls the motor speed to maximum 120rpm for the both shot and suck-back function. With the Real&Time mode, ON/OFF control or time setting control are available.



| Model | BP-2 |
|-----------------------|--|
| Interface | RS485(Male), D-SUB 9 pin |
| Input/Output Signal | Shot, Channel No, User Optional / End Signal, Error Signal |
| Air IN-Port | 6Ø Air Hose |
| Air OUT-Port | Auto Coupler |
| Pressure Regulator | 0~7kgf/cm ² |
| Operation Mode | Time / Real |
| Display | 4.3" TFT LCD, Touch Panel |
| Motor | DC Servo Motor |
| External Control | Input 8 CH, Output 8 CH |
| Channel Memory | Internal: 200 CH, External: 16 CH |
| Consumption Rating | AC 80~220C(Pre Volt), 50/60Hz |
| Operating Temperature | 10~40°C |
| Optional System | Dispensing Pressure Check (for 2 Parts only) |
| Dimension & Weight | 220(W) x 224(D) x 120(H)mm / 1.8kg |

TUBING DISPENSING CONTROLLER

BX-2

Tubing Dispenser

This controller is volumetric tubing dispenser which is not using air pressure but its rotating pump head pushes the fluid material in the tube and dispense precise amount of the material. The tube goes directly in the fluid container, and the fluid in the tube is dispensed due to the pressure difference made by pump head rotation. The controller is suitable for the low viscosity and anaerobic fluid material application.



| Model | BX-2 |
|-----------------------------|--|
| Control Method | Electronic / Pneumatic System |
| Dispensing pressure | 0.15kg/cm ² |
| Time Range | 0.01~99.99 sec |
| Rotor Speed | 0~120rpm(max.) |
| Flow Speed | 0.01~6ml/min.(Teflon Tube) 0.1~20ml/min.(Silicone Tube) |
| Material Viscosity | 300cps(max.) |
| Pump Direction | Both Direction(Forward & Reverse) |
| Power source | AC100~220V 50/60Hz(Free voltage) |
| External Dimension & weight | 190(W) x 165(D) x 81(H)mm, 2.6kg |

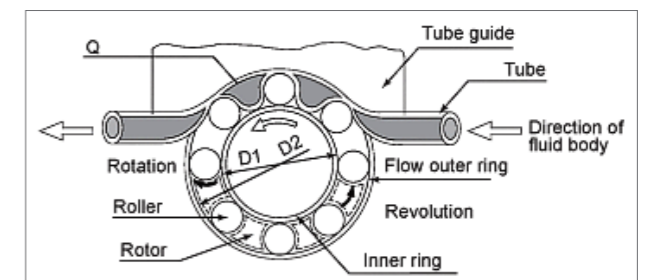

DISPENSING VALVE

NEEDLE-OFF VALVE

The valve operates as the needle-shaped pin stuck in the fluid outlet falls off.
 This type of valve does not make the Head: A clumped fluid material made at the beginning of the line dispensing. Needle Off type is often used for the high pressure valve.

BV-302

The basic valve of Needle-Off type.
 Suitable for the low-medium viscosity fluid material, where application requires small amount dispensing.



BV-386

Needle Off type valve for the high viscosity.
 Suitable for the application using high pressure&high viscosity fluid material of 1cps~paste.

BV-3893

Large capacity version of BV-386.



BV-3892

Larger orifice size version of BV-3893.
 Suitable for the application where big amount dispensing is required.



| Model | BV-302 | BV-386 | BV-3892 | BV-3893 |
|----------------------------|----------------------|------------------------|------------------------|------------------------|
| ON/OFF Method | Needle Off | Needle Off | Needle Off | Needle Off |
| Applicable viscosity | 1~100,000cps | 1~PASTE | 1~1,000,000cps | 1~1,000,000cps |
| Input Air Pressure | 4kgf/cm ² | 5kgf/cm ² | 5kgf/cm ² | 5kgf/cm ² |
| Max. fluid IN-LET pressure | 6kgf/cm ² | 150kgf/cm ² | 210kgf/cm ² | 210kgf/cm ² |
| Max. operation number | 150times/min | 150times/min | 150times/min | 240times/min |
| IN-LET Fittings | PT 1/8" | PT 1/4" | PT 1/2" | PT 1/4" |
| Wet-part material | SUS 303 | SUS 303 | SUS 303 | SUS 303 |
| Valve material | AL 6061 | AL 6061 | AL 6061 | AL 6061 |
| Weight | 290g | 680g | 2540g | 820g |

DISPENSING VALVE

PRECISION VALVE

A needle off type valve for small amount, low viscosity fluid dispensing, designed to set the fine dispense amount by adjusting the pin stroke of the valve.

BV-520M

A precision valve.

The stroke of the needle pin is adjustable, therefore precise amount dispensing is available.



BV-520P

Precision Nozzle version of BV-520.



BV-520PK

BV-520 valve used for anaerobic UV material & adhesive application. The valve is suitable for the anaerobic fluid material due to PEEK material applied to a wet part. Both needle type or precision nozzle type can be used.



| Model | BV-520M | BV-520P | BV-520PK |
|----------------------------|-----------------------|-----------------------|----------------------|
| ON/OFF Method | Needle Off | Needle Off | Needle Off |
| Applicable viscosity | 1~100,000cps | 1~100,000cps | 1~100,000cps |
| Input Air Pressure | 5kgf/cm ² | 5kgf/cm ² | 5kgf/cm ² |
| Max. fluid IN-LET pressure | 10kgf/cm ² | 10kgf/cm ² | 6kgf/cm ² |
| Max. operation number | 240times/min | 240times/min | 240times/min |
| IN-LET Fittings | PT 1/8" | PT 1/8" | PT 1/8" |
| Wet-part material | SUS 303 | SUS 303 | PEEK |
| Valve material | SUS 303 | SUS 303 | SUS 303 |
| Weight | 300g | 300g | 300g |

DISPENSING VALVE

SUCK BACK VALVE

The valve operates as the fluid outlet is closed by pulling the pin, dispensed as the pin falls off. This type of valve does not make the Tail: A clumped fluid material made at the end of the line dispensing. Often used in applications that require vacuum process to remove the remaining pressure after dispensing.

BV-303

Basic type of Suck Back valve.
Suitable for the low-midium viscosity fluid material, where application requires small amount dispensing.



BV-325

Large capacity version of BV-303.



BV-396

Larger orifice size version of BV-325.
Suitable for the high pressure & high viscosity application up to 500,000cps.

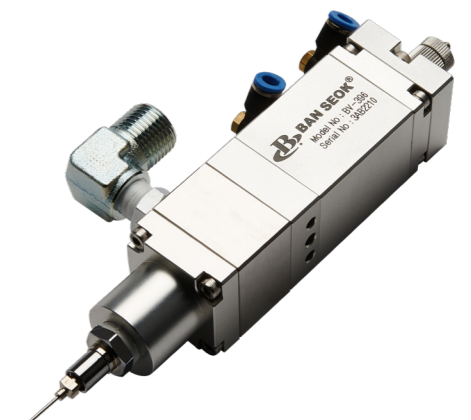

| Model | BV-303 | BV-325 | BV-396 |
|----------------------------|-----------------------|-----------------------|------------------------|
| ON/OFF Method | Suck Back | Suck Back | Suck Back |
| Applicable viscosity | 1~200,000cps | 1~200,000cps | 1~500,000cps |
| Input Air Pressure | 5kgf/cm ² | 5kgf/cm ² | 5kgf/cm ² |
| Max. fluid IN-LET pressure | 30kgf/cm ² | 50kgf/cm ² | 150kgf/cm ² |
| Max. operation number | 150times/min | 150times/min | 150times/min |
| IN-LET Fittings | PT 1/8" | PT 1/4" | PT 3/8" |
| Wet-part material | AL 6061 | AL 6061 | AL 6061 |
| Valve material | AL 6061 | AL 6061 | AL 6061 |
| Weight | 240g | 300g | 300g |

DISPENSING VALVE

SPRAY VALVE

A Conformal coating valve with the spraying function. The valve operates as the needle off function and sprays the dispensed fluid with internal air blow function. Products can be selected according to the application and required scattering degree.

BV-500 ①

A spray dispensing valve.
The valve can control the spraying width of minimum 7mm according to the height.



①

BV-500T ②

A precise spraying valve with little scattering. The “Tornado” technology is applied on the valve, therefore provide more precise spray dispensing.



②

BV-500P ③

Conformal coating valve with uniform spraying with improved internal airflow structure. To treat the quick-curing conformal coating fluid, the nozzle is placed inside the valve, therefore, providing an equal dispensed shape, and is easy to clean when cured.

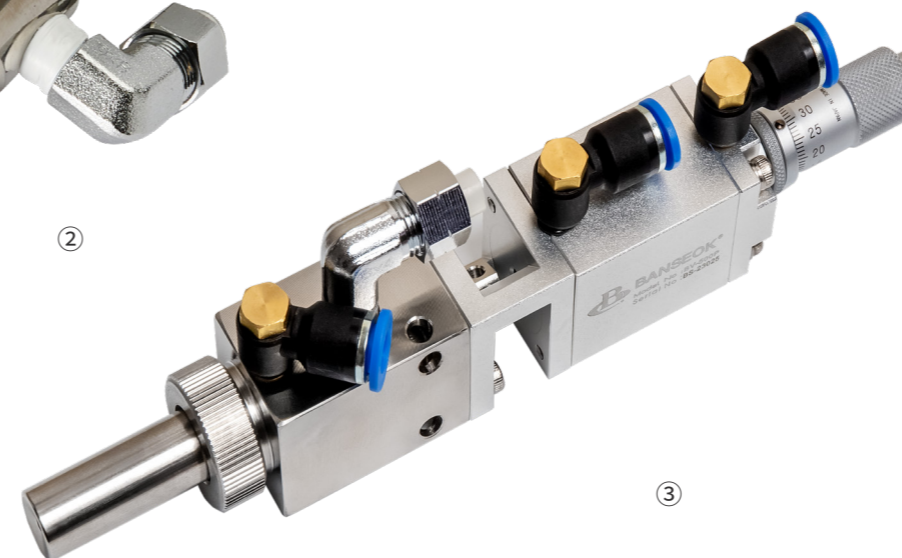

③

| Model | BV-500 | BV-500T | BV-500P |
|----------------------------|-----------------------|-----------------------|-----------------------|
| ON/OFF Method | Needle Off | Needle Off | Needle Off |
| Applicable viscosity | 1~1,000cps | 1~1,000cps | 1~1,000cps |
| Input Air Pressure | 5kgf/cm ² | 5kgf/cm ² | 5kgf/cm ² |
| Max. fluid IN-LET pressure | 10kgf/cm ² | 10kgf/cm ² | 10kgf/cm ² |
| Max. operation number | 240times/min | 240times/min | 240times/min |
| IN-LET Fittings | PT 1/8" | PT 1/8" | PT 1/8" |
| Wet-part material | SUS 303 | SUS 303 | SUS 303 |
| Valve material | SUS 303 | SUS 303 | SUS 303 |
| Weight | 285g | 340g | 400g |
| Control | - | - | Double-Action |
| Stroke Control | - | - | Micrometer |

DISPENSING VALVE

METERING VALVE

A precise metering valve with a dispensing error rate of 1%.
The valve has the volume metering principle that measures required volume and dispense in even amount.

BV-M0250T

Precise metering valve with a shot size minimum 0.025cc to maximum 0.25cc. Suitable for the low viscosity, small amount application.

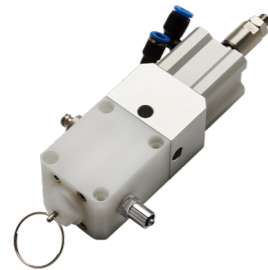

BV-M06

A precision metering valve for high viscosity with a dispensing error rate of 1%. A shot dispenses minimum 0.2cc to 6cc.

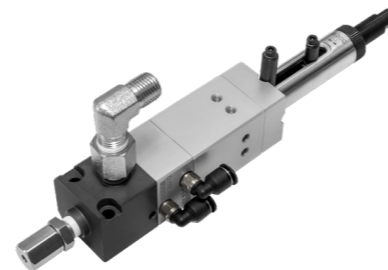

| Model | BV-M0250T | BV-M06 |
|----------------------------|---------------------------|------------------------|
| ON/OFF Method | Metering | Metering |
| Applicable viscosity | 1~5,000cps | MAX 1,000,000cps |
| Input Air Pressure | 4kgf/cm ² | 2~7kgf/cm ² |
| Max. fluid IN-LET pressure | 4kgf/cm ² | 250kgf/cm ² |
| Max. operation number | 180times/min | 90cycle/min |
| IN-LET Fittings | PT 1/4"(in), PT 1/8"(out) | PT 1/8" |
| Wet-part material | SUS 304 | SUS 304 |
| Valve material | AL 6061 | AL 6061 |
| Weight | 700g | 420g |
| Accuracy | .+- 1% | .+- 1% |

ACTUATOR VALVE

The valve is controlled in rotary principle, therefore there is no Head or Tail which is clumped fluid material made during the line dispensing.

BV-600C

An actuator valve removes the remaining pressure after dispensing and prevents dripping of the fluid at the end of the needle.



| Model | BV-600C |
|----------------------------|-----------------------|
| ON/OFF Method | Rotary |
| Applicable viscosity | 10,000~600,000cps |
| Input Air Pressure | 5kgf/cm ² |
| Max. fluid IN-LET pressure | 21kgf/cm ² |
| Max. operation number | 150times/min |
| IN-LET Fittings | PT 5/16",M6 |
| Wet-part material | Ceramic |
| Valve material | AL 6061 |
| Weight | 420g |

DISPENSING VALVE

DIAPHRAGM VALVE

A valve for low viscosity and low pressure, using diaphragm operation. A fluid hole and the round plate-shaped diaphragm fit in the valve. The valve opens when these fall off and closes when these meet. The material of the diaphragm is suitable for anaerobic and chemical-resistant material.

| Model | BV-300N | BV-300T |
|----------------------------|----------------------|----------------------|
| ON/OFF Method | Diaphragm | Diaphragm |
| Applicable viscosity | 1~5,000cps | 1~5,000cps |
| Input Air Pressure | 4kgf/cm ² | 4kgf/cm ² |
| Max. fluid IN-LET pressure | 5kgf/cm ² | 5kgf/cm ² |
| Max. operation number | 240times/min | 240times/min |
| IN-LET Fittings | PT 1/8" | PT 1/8" |
| Wet-part material | UPE | TEFLON |
| Valve material | AL 6061 | AL 6061 |
| Weight | 76g | 76g |

BV-300N

A diaphragm valve which is suitable for the anaerobic fluid due to applied UPE material on the valve. Suitable for the low viscosity fluid material.



BV-300T

A diaphragm valve which is suitable for the anaerobic, chemical resistant and UV material that applied Teflon to the wet part. Suitable for the low viscosity fluid material.



TWO LIQUID TYPE VALVE

A two-fluid type valve to dispense 2K materials of resin and hardener. The valve is designed to fasten various types of mixers to the fluid outlet, so the valve can be used after replacing mixers without additional cleaning. Two types can be selected depending on the dispensing amount.

| Model | BV-T900 | BV-T900-MINI |
|----------------------------|-----------------------|-----------------------|
| ON/OFF Method | Suck Back | Suck Back |
| Applicable viscosity | 1~PASTE | 1~PASTE |
| Input Air Pressure | 5kgf/cm ² | 5kgf/cm ² |
| Max. fluid IN-LET pressure | 60kgf/cm ² | 60kgf/cm ² |
| Max. operation number | 60times/min | 60times/min |
| IN-LET Fittings | PT 1/4" | PT 1/4" |
| Wet-part material | AL 6061 | AL 6061 |
| Valve material | AL 6061 | AL 6061 |
| Weight | 1040g | 413g |

BV-T900

A two-fluid type suck back valve for high viscosity material.

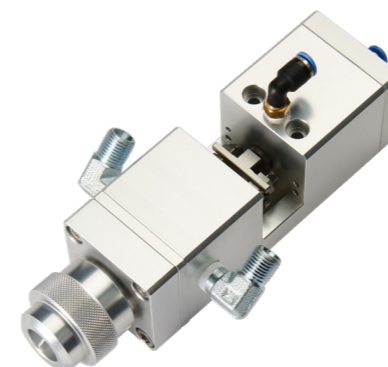

BV-T900-MINI

A compact size version of BV-T900. Suitable for the small amount dispensing.

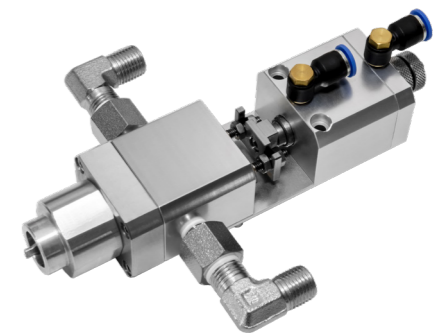

PRESSURE TANK

CUSTOMIZING

A customized tanks with Banseok Precision's customizing system.

The Tank is a large volume fluid container for low-medium viscosity fluid material.

It is used for applications that require large volume dispensing or frequent filling of materials.

Various types and options can be selected depending on the application.



1 Tank Type

BMT / BST / BFT

2 Volume

BMT: Customizing

BST: Max 20L

BFT: Max 8L

3 Port

BP: Bottom Port

TP: Top Port

4 L/S/V

L: Level Gauge (Ø6, Ø8 PFA Tube)

S: Level Sensor, Float Sensor

V: Vision

5 Heater

TANK OPTION

Teflon Coating

Teflon Coating can be selected for applications that require chemical resistance, such as anaerobic fluid material.



Hopper (supplementary fluid filler)

An auxiliary fluid inlet to make fluid materials filling more convenient. Used to simplify the process of opening and closing the heavy clamps of large-volume tanks.



Internal Container

Internal container can be installed for user convenience of fluid filling, cleaning, and stirring.



Vacuum Agitator

An option to vacuum the pressure of the tank to remove air bubbles from the fluid material. Applied to the tank when the fluid material is not in low viscosity.



Load Cell System

A scale system that measures the amount of material. Various resolutions and specifications are selectable depending on the weight and size.



Tank Heater

A Heating option to prevent hardening of the fluid in the containers or to reduce the viscosity.



PRESSURE TANK

The suitable tank among three types can be selected depending on the amount and viscosity of the fluid material in the tank used for the application. You can customize the options you need to each tank types.



①



②



③

BFT Type ①

Simple clamp type tank to transfer low viscosity fluid material.



BST Type ②

Vertical shaped tank used for fluid material under 20L volume.



BMT Type ③

Hinge clamp type tank used for the large volume, high pressure application.



PRESSURE PUMP

CARTRIDGE PUMP

BSP-330S

A device to supply high viscosity cartridge-type fluid without exposure to air or loss of materials using a pump pressure.

| Model | BSP-330S |
|--------------------------|-------------------------------|
| Air pressure | Min. 2kgf/cm ² |
| Air consumption | 80ml/min(max) |
| Pump sending ratio | 10:1, 20:1(For high pressure) |
| Max. dispensing pressure | 50kgf/cm ² |
| Min. dispensing pressure | 0.005cc/shot |
| Applied viscosity | 10,000~600,000cps |
| Applied container | 300ml,310ml,330ml cartridge |
| Power | AC220V 50/60Hz (110V:Option) |



BSP-330D

A dual cylinder type device that supplies high viscosity cartridge-type fluid material without exposure to air or loss of materials using a pump pressure. Once the fluid material in the cartridge 1 is used up, the pump automatically supplies the fluid in the cartridge 2, therefore continuous operation is possible during the cartridge replacement.

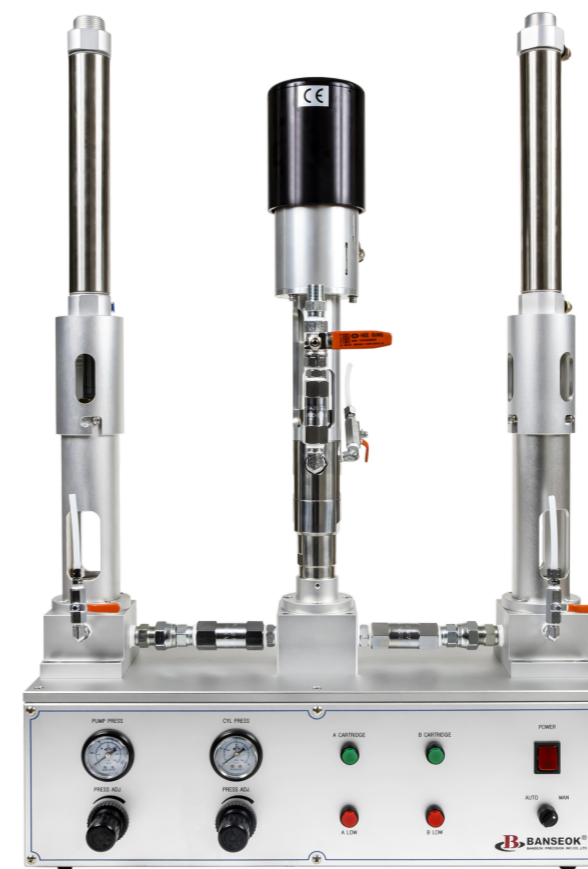

| Model | BSP-330D |
|--------------------------|-------------------------------|
| Air pressure | Min. 2kgf/cm ² |
| Air consumption | 80ml/min(max) |
| Pump sending ratio | 10:1, 20:1(For high pressure) |
| Max. dispensing pressure | 50kgf/cm ² |
| Min. dispensing pressure | 0.005cc/shot |
| Applied viscosity | 10,000~600,000cps |
| Applied container | 300ml,310ml,330ml cartridge |
| Power | AC220V 50/60Hz (110V:Option) |

PRESSURE PUMP

CAN PUMP

PCP-a135

A can pressure pump to transfer the compressed high viscosity fluid material in 1,3,5kg can.

| Model | PCP-a135 |
|--------------------|-------------------------------|
| Pump Sending Ratio | 10:1, 20:1(For high pressure) |
| Applying Viscosity | 10,000~400,000cps |
| Air Pressure | 1~7bar |
| Air Consumption | 80ml/min(max) |
| Applying Container | 1kg, 3kg, 5kg |
| Power | AC220V 50/60Hz(110V:Option) |

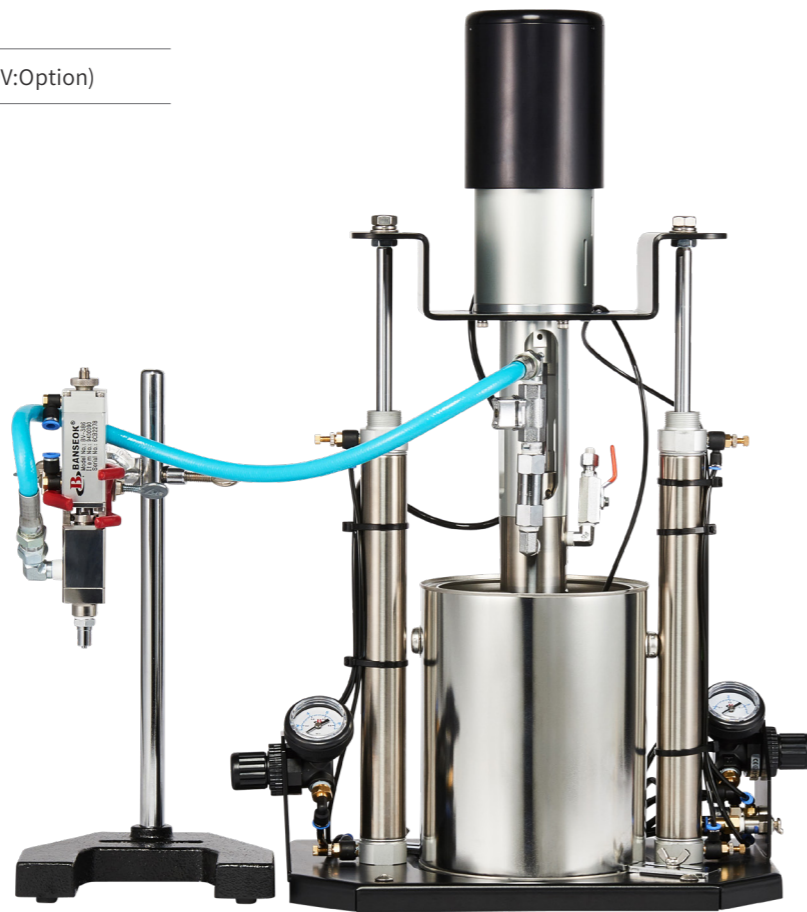

PCP-20-10

A can pressure pump to transfer the compressed high viscosity fluid material in 20kg can with the pneumatic pressure of 10:1 pump sending ratio. It can be applied up to 400,000cps of high viscosity fluid.



| Model | PCP-20-10 |
|--------------------|-------------------------------|
| Pump Sending Ratio | 10:1, 20:1(For high pressure) |
| Applying Viscosity | 10,000~400,000cps |
| Air Pressure | 1~7bar |
| Air Consumption | 80ml/min(max) |
| Applying Container | - |
| Power | AC220V 50/60Hz(110V:Option) |



PRESSURE PUMP

CAN PUMP

PCP-20-55

A can pressure pump to transfer the compressed high viscosity fluid material in 20kg can with the pneumatic pressure of 55:1 pump sending ratio. It can be applied to minimum 50,000cps to maximum 1,000,000cps of high viscosity fluid.

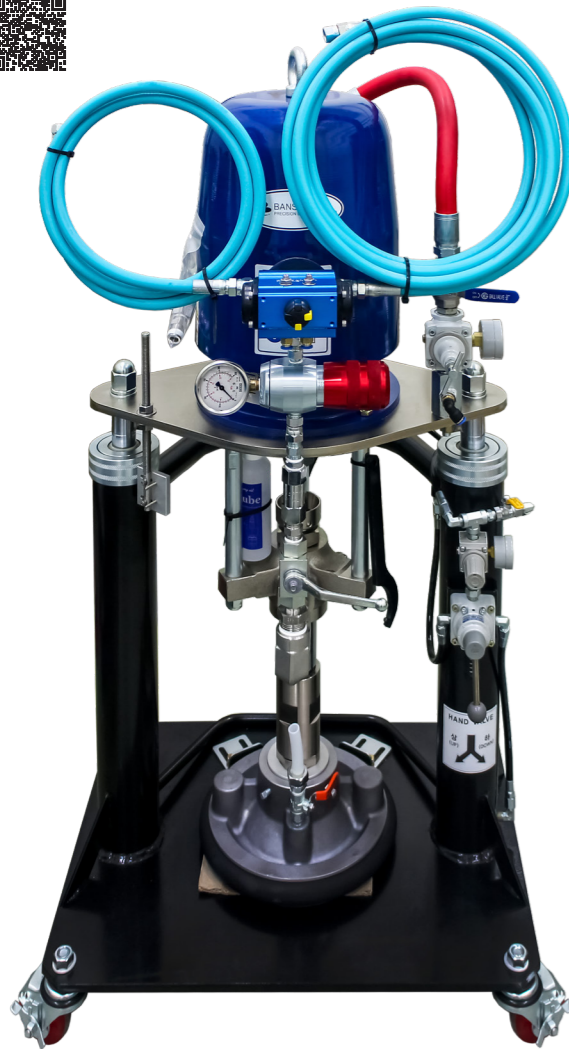

| Model | PCP-20-55 |
|-----------------------|-------------|
| Pump Sending Ratio | 55:1 |
| Delivery | 10L/Min |
| Air Pressure | 3~7bar |
| Cycle Per Liter | 263 Cycle/L |
| Max. Working Pressure | 385bar |
| Max. Pump Speed | 60Cycle/Min |
| Air Motor Dia | 161mm |
| Stroke | 90mm |

PUMP ACCESSORIES

AOPR

AOPR is a pneumatic fluid pressure regulator with enhanced performance than FPR, which adjusts the pulsation of high-pressure fluid materials from the pump to around 5% of error rate.

| Model | AOPR |
|----------------------------------|------------|
| Actuation Type | Air |
| Flow control Type | Regulation |
| Gauge Port Size (in) | 3/4 |
| Gauge Port Type | NPT |
| Inlet Size | 3/4 |
| Inlet Thread Type | NPT |
| Maximum Regulated Pressure (Mpa) | 31.0 |
| Maximum Regulated Pressure (psi) | 4,500 |
| Maximum Viscosity (cP) | 80,000 |
| Maximum Working Pressure (Mpa) | 34.4 |



FPR

The FPR is a fluid pressure regulator that controls the pulsation of the high pressure fluid material from the pump and reduces the pressure to a suitable and safe pressure for use in subsequent stages of dispensing.

| Model | FPR |
|------------------------|--|
| Maximum Inlet Pressure | |
| Governing Field | 70 - 320bar (1,000-5,000 psi) (RED) 20 - 70bar (0-1,000 psi) (BLUE) |
| Maximum Delivery | 8 Liter/min (2.1 gallon per min) |
| Fluid Inlet | 3/8" NPT(F) |
| Fluid Outlet | 1/4" NPT(F) |



DISPENSING PUMP

PROGRESSIVE CAVITY PUMP

Banseok Smart PC Pump is a volumetric dispensing pump with dispensing error rate of less than 1% using a stator and a rotor.

With the Motor Pulse Control and Suck Back functions, fluids of various viscosity up to 100,000 cps can be controlled with its own controller and pump without remaining pressure after dispensing.

A compact size and the intuitive structure enables customers to disassemble and clean easily.



BPP-050



BPP-100



BPP-500



BPP-1000

ENDLESS PISTON PRINCIPLE

Banseok PC Pump are based on a completely pressure tight displacement system, which is self-sealing and consists of a rotor and stator. The controlled motor enables a constant volume to be conveyed proportionally to the angle per revolution.

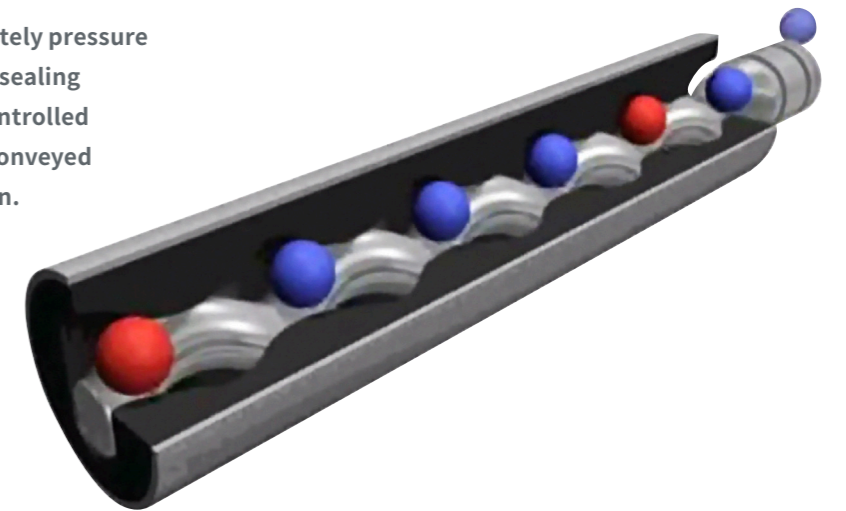

| Model | BPP-050 | BPP-100 | BPP-500 | BPP-1000 |
|------------------------------|------------------------|------------------------|------------------------|------------------------|
| Dispensing Volume(60rpm/sec) | ≒0.05ml | ≒0.1ml | ≒0.5ml | ≒1ml |
| Motor Speed | 1~120rpm | 1~120rpm | 1~120rpm | 1~120rpm |
| Accuracy | ±1% | ±1% | ±1% | ±1% |
| Input Air Pressure | 0~6kgf/cm ² | 0~6kgf/cm ² | 0~6kgf/cm ² | 0~6kgf/cm ² |
| Material of Stator | FFKM | FFKM | FFKM | FFKM |
| Material of Motor | Stainless Steel | Stainless Steel | Stainless Steel | Stainless Steel |
| Inlet Port | G 1/8"(STD) | G 1/4"(STD) | G 1/8"(STD) | G 1/4"(STD) |
| Outlet Port | Luer Lock | Luer Lock | Luer Lock | Luer Lock |
| Wetting Part Material | SUS / UHMW-PE | SUS / UHMW-PE | SUS / UHMW-PE | SUS / UHMW-PE |
| Weight | 540g | 1.6kg | 540g | 1.6kg |
| Operating Condition | 10~40°C | 10~40°C | 10~40°C | 10~40°C |

DISPENSING PUMP

GEAR PUMP

A volumetric pump which operates with the two gears engaged. The cavity generated between them dispenses even amount per cycle. Fluid of various volumes can be precisely controlled with a dispensing error of less than 1%.

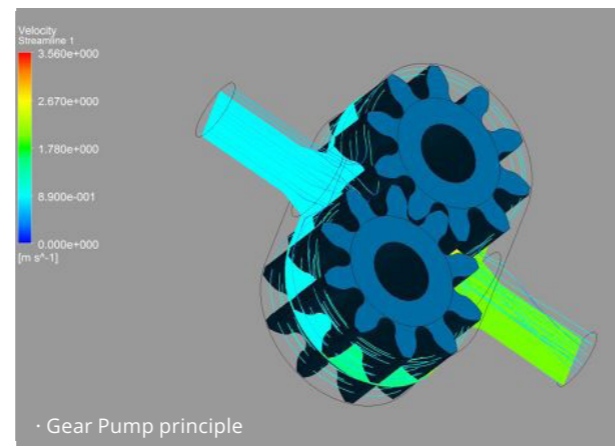
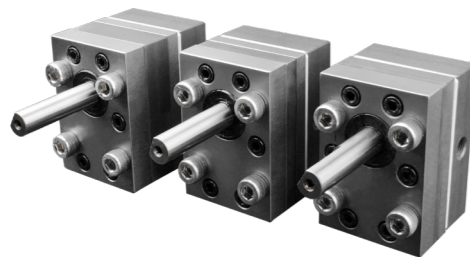

MMA

The Unit dispenses the dual cartridge type fluid material of diverse viscosity with precise control using SERVO/STEP motor and the Ball Screw operation. It automatically adjusts the mixing ratio of various volumes of dual cartridge type fluid. The Suck Back function of the MMA prevents the dripping phenomenon due to the remaining pressure.



| Model | MMA |
|--------------------|---------------------|
| Dispensing Speed | Max. 500ml/sec |
| Operation Accuracy | 0.01mm |
| Repeat Accuracy | ±0.02mm |
| Operation Metion | SERVO/STEP |
| Power | AC220V 50-60Hz 250W |

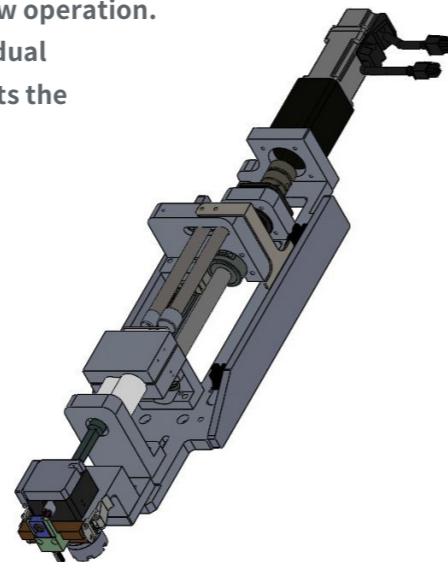

SYRINGE PUMP

BS-1

A syringe type dispensing pump to control low viscosity fluid used in the application as bio-technology. The low viscosity fluids are controlled by the STEP motor using its syringe. The unit provides the best resolution of 2,000:1 with an error rate of 1%.



| Model | BS-1 | |
|--------------------|-----------------------|---|
| Power requirements | Voltage | 24 VDC |
| | Current | 1 amp maximum |
| Syringes | Sizes | 25ul, 50ul, 100ul, 250ul, 500ul, 1ml, 2.5ml, 5ml, 10ml, 25ml |
| | Fluid contact | Glass, PTFE, CTFE, UHMWPE |
| Syringe drive | Drive type | DC stepper motor: self lubricating and wear compensating lead nut/screw |
| | Travel/speed | 2 to 60 seconds/stroke |
| | Resolution | Half 1,000 counts, Full 2,000 counts |
| | Accuracy | ±1.0% > 30% stroke |
| | Precision | +0.2% > 30% stroke |
| Valve drive | Valves | Ceramic or rotating plug |
| | Drive type | Stepper motor with encoder |
| | Speed | 500 ms 90° |
| | Fluid contact | PTFE & CTFE or ceramic |
| Environment | Fittings | 1/4 - 28 |
| | Operating temperature | 60°F to 95°F (15°C to 25°C) |
| | Operating humidity | 20% to 90%, non-condensing |

GEAR PUMP COMPOUND UNITS

The units that can be controlled with a dispensing error of less than 1% by combining Banseok's various & verified equipments with Gear Pump.

PGP-20-10

A gear pump compounded PCP-20-10 which supplies the material pumped from the 20kg can to the Gear Pump stage directly and dispenses the high viscosity fluid material up to 400,000 cps with a precise dispensing accuracy of 1%.



BRGP

A gear pump compounded 330ml cartridge pump. The fluid in the 330ml cartridge transfers directly to the Gear Pump stage and is supplied to the valve using the SERVO motor of the Gear Pump. Suitable for dispensing high viscosity fluid material in the 330ml cartridge, without the loss of fluid material or pulsation.



TAD-175G

TAD-175G is a Gear Pump dispensing system which is directly connected to the fluid supplying unit. A Gear Pump using a SERVO motor dispenses the fluid material with 1% of high accuracy without pulsation.

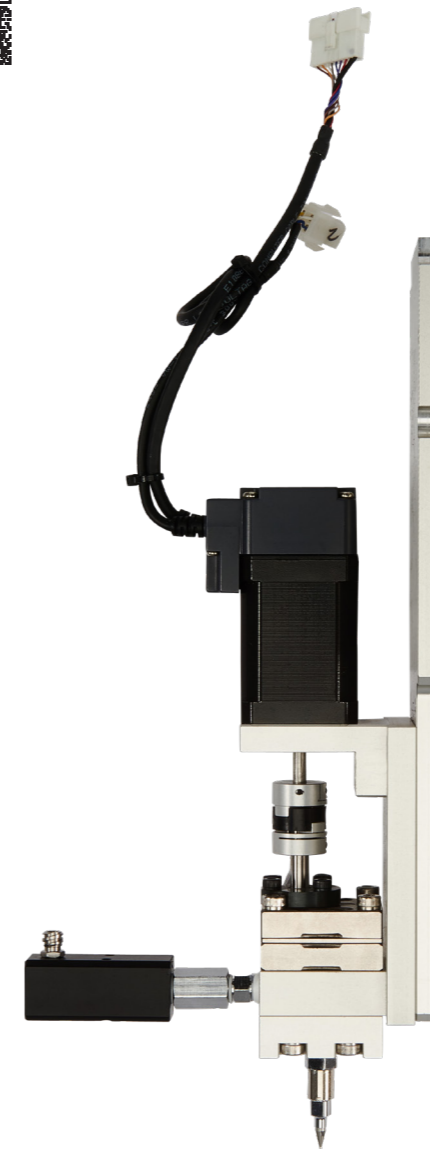

| Model | PGP-20-10 / BRGP |
|-----------------|--|
| cc/Rev | Customizing |
| Inlet Pressure | Max.2MPa(Max.20kgf/cm ²) |
| Outlet Pressure | Max.5MPa(Max.50kgf/cm ²) |
| Viscosity | 10,000~400,000cps |
| Precision | ±2% |
| Power Source | AC220C,50/60Hz |
| Material | Alloy Tool Steel, Stainless Steel, Aluminium |

| Model | TAD-175G |
|----------------------|--|
| Application | Silicone, Urethane, Epoxy, Polyester, Nylon, Polypropylene |
| Material | High Speed Tool Steel |
| Weight | 1.92kg |
| Rotation Speed | 10~40 Rev/min |
| Rotation Sense | Clockwise |
| Inlet Pressure | Max. 50kg/cm ² |
| Outlet Pressure | Max. 380kg/cm ² |
| Viscosity of Polymer | 1,000~500,000cps |

ROBOTS

DESKTOP

BT-200FN



BT-300FN



BT-400FN

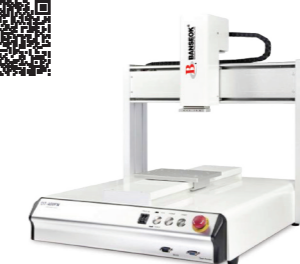

BT-500FN



| Model | BT-200FN | BT-300FN | BT-400FN | BT-500FN |
|--|---------------------------------------|---------------------------------------|---------------------------------------|---------------------------------------|
| Working Area X / Y / Z (mm) | 200 / 200 / 50 | 300 / 300 / 100 | 400 / 400 / 100 | 500 / 500 / 100 |
| Load Worktable Y-Axis / Z-Axis | 5kg / 3kg | 10kg / 5kg | 10kg / 5kg | 10kg / 5kg |
| Maximum Speed XY / Z (mm/sec) | 0.1 ~ 500 / 300 | 0.1 ~ 600 / 300 | 0.1 ~ 600 / 300 | 0.1 ~ 600 / 300 |
| Resolution | 0.001mm / Axis | 0.001mm / Axis | 0.001mm / Axis | 0.001mm / Axis |
| Repeatability | +/- 0.01mm / Axis | +/- 0.01mm / Axis | +/- 0.01mm / Axis | +/- 0.01mm / Axis |
| Data Memory Capacity | 100 programs 4000 points / program | 100 programs 4000 points / program | 100 programs 4000 points / program | 100 programs 4000 points / program |
| Display | TFT | TFT | TFT | TFT |
| Drive System / Stepping Motor | Micro stepping motor | Micro stepping motor | Micro stepping motor | Micro stepping motor |
| Motion Control | PTP & CP | PTP & CP | PTP & CP | PTP & CP |
| Linear / Circular Interpolation | 3 axis | 3 axis | 3 axis | 3 axis |
| Teaching Method | Teach pendant | Teach pendant | Teach pendant | Teach pendant |
| I/O Signals | 8 Inputs / 8 Outputs | 8 Inputs / 8 Outputs | 8 Inputs / 8 Outputs | 8 Inputs / 8 Outputs |
| Power Supply | 100 ~ 230 VAC , 200 W | 100 ~ 230 VAC , 320 W | 100 ~ 230 VAC , 320 W | 100 ~ 230 VAC , 320 W |
| Working Temperature | 0 ~ 40°C | 0 ~ 40°C | 0 ~ 40°C | 0 ~ 40°C |
| Relative Humidity (no condensation) | 20 - 90% No condensation | 20 - 90% No condensation | 20 - 90% No condensation | 20 - 90% No condensation |
| Dimensions (WxDxH mm) | 382 × 374 × 485 | 482 × 499 × 593 | 585 × 599 × 597 | 685 × 698 × 593 |
| Robot Weight | 23kg | 30kg | 40kg | 45kg |

ROBOTS

DESKTOP

BT-500Q2Y



| Model | BT-500Q2Y |
|-------------------------------------|---|
| Working Area X / Y1 / Y2 / Z (mm) | 500 / 500 / 500 / 100 |
| Load Worktable Y-Axis / Z-Axis | 5 kg / 5 kg |
| Maximum Speed XY / Z (mm/sec) | 0.1 ~ 600 / 300 |
| Resolution | 0.001 mm / Axis |
| Repeatability | +/- 0.01 mm / Axis |
| Data Memory Capacity | 100 programs · 4000 points / program |
| Display | TFT |
| Drive System / Stepping Motor | Micro stepping motor |
| Motion Control | PTP & CP |
| Linear / Circular Interpolation | 3 axis / 2Y |
| Teaching Method | Teach pendant |
| I/O Signals | 8 Inputs / 8 Outputs |
| Power Supply | 100 ~ 230 VAC , 320 W |
| Working Temperature | 0 ~ 40° C |
| Relative Humidity (no condensation) | 20 - 90% No condensation |
| Dimensions (WxDxH mm) | 685 x 715 x 670 |
| Robot Weight | 70 kg |

BT-HR Series



| Model | BT-300HR | BT-400HR | BT-500HR |
|-------------------------------------|---|---|---|
| Working Area X / Y / Z (mm) | 300 / 300 / 100 / 360° | 400 / 400 / 100 / 360° | 500 / 500 / 100 / 360° |
| Load Worktable Y-Axis / Z-Axis | 10 kg / 2 kg | 10 kg / 2 kg | 10 kg / 2 kg |
| Maximum Speed XY / Z (mm/sec) | 0.1 ~ 500 / 300 | 0.1 ~ 500 / 300 | 0.1 ~ 500 / 300 |
| Resolution | 0.001 mm / Axis | 0.001 mm / Axis | 0.001 mm / Axis |
| Repeatability | +/- 0.02 mm / Axis | +/- 0.02 mm / Axis | +/- 0.02 mm / Axis |
| Data Memory Capacity | 100 programs · 4000 points / program | 100 programs · 4000 points / program | 100 programs · 4000 points / program |
| Display | TFT | TFT | TFT |
| Drive System / Stepping Motor | servo motor | servo motor | servo motor |
| Motion Control | PTP & CP | PTP & CP | PTP & CP |
| Linear / Circular Interpolation | 3 axis | 3 axis | 3 axis |
| Teaching Method | Teach pendant | Teach pendant | Teach pendant |
| I/O Signals | 8 Inputs / 8 Outputs | 8 Inputs / 8 Outputs | 8 Inputs / 8 Outputs |
| Power Supply | AC110 ~ 220 VAC , 300 W | AC110 ~ 220 VAC , 300 W | AC110 ~ 220 VAC , 300 W |
| Working Temperature | 0 ~ 40° C | 0 ~ 40° C | 0 ~ 40° C |
| Relative Humidity (no condensation) | 20 - 90% No condensation | 20 - 90% No condensation | 20 - 90% No condensation |
| Dimensions (WxDxH mm) | 485 x 505 x 797 | 585 x 605 x 797 | 685 x 698 x 797 |
| Robot Weight | 37 kg | 47 kg | 55 kg |

ROBOTS

DESKTOP

BT-S Series



| Model | BT-320S | BT-420S |
|-------------------------------------|--------------------------------------|--------------------------------------|
| Working Area X / Y / Z (mm) | 320 / 350 / 100 | 420 / 350 / 100 |
| Load Worktable Y-Axis / Z-Axis | 10 kg / 5 kg | 10 kg / 5 kg |
| Maximum Speed XY / Z (mm/sec) | 0.1 ~ 600 / 300 | 0.1 ~ 600 / 300 |
| Resolution | 0.001 mm / Axis | 0.001 mm / Axis |
| Repeatability | +/- 0.01 mm / Axis | +/- 0.01 mm / Axis |
| Data Memory Capacity | 100 programs · 4000 points / program | 100 programs · 4000 points / program |
| Display | TFT | TFT |
| Drive System / Stepping Motor | DC servo motor | DC servo motor |
| Motion Control | PTP & CP | PTP & CP |
| Linear / Circular Interpolation | 3 axis | 3 axis |
| Teaching Method | Teach pendant | Teach pendant |
| I/O Signals | 8 Inputs / 8 Outputs | 8 Inputs / 8 Outputs |
| Power Supply | 100 ~ 230 VAC , 320 W | 100 ~ 230 VAC , 320 W |
| Working Temperature | 0 ~ 40° C | 0 ~ 40° C |
| Relative Humidity (no condensation) | 20 - 90% No condensation | 20 - 90% No condensation |
| Dimensions (WxDxH mm) | 482 x 499 x 593 | 585 x 599 x 597 |
| Robot Weight | 30 kg | 40 kg |

BT-LV Series



| Model | BT-320LV | BT-420LV |
|-------------------------------------|--|--|
| Working Range X / Y / Z (mm) | 320 / 350 / 100 | 420 / 350 / 100 |
| Load Worktable Y-Axis / Z-Axis | 10 kg / 5 kg | 10 kg / 5 kg |
| Maximum Speed XY / Z (mm/sec) | 0.1 ~ 500 / 300 | 0.1 ~ 500 / 300 |
| Resolution | 0.001 mm / Axis | 0.001 mm / Axis |
| Repeatability | +/- 0.01 mm / Axis | +/- 0.01 mm / Axis |
| Data Memory Capacity | 4000 points / program | 4000 points / program |
| Program Display | 19" LCD Monitor | 19" LCD Monitor |
| Data Storage Type | PC HD Storage | PC HD Storage |
| Drive System / Stepping Motor | X / Y-axis DC servo motor, Z-axis High resolution stepping motor | X / Y-axis DC servo motor, Z-axis High resolution stepping motor |
| Driver System | X / Y / Z axis ball screw driven | X / Y / Z axis ball screw driven |
| Motion Control | PTP & CP | PTP & CP |
| Linear / Circular Interpolation | 3 axis | 3 axis |
| Programming Method | Windows software | Windows software |
| I/O Signals | 8 Inputs / 8 Outputs | 8 Inputs / 8 Outputs |
| Power Supply | 100 ~ 230 VAC , 320 W | 100 ~ 230 VAC , 320 W |
| Working Temperature | 0 ~ 40° C | 0 ~ 40° C |
| Relative Humidity (no condensation) | 20 - 90% No condensation | 20 - 90% No condensation |
| Dimensions (WxDxH mm) | 558 x 647 x 630 | 647 x 685 x 597 |
| Robot Weight | 60 kg | 70 kg |

ROBOTS

DESKTOP

MDR Desktop Robot Series



EASYRO DESKTOP ROBOT ①

| Model | | 331 | 441 | 3351 | 4461 | |
|----------------|------------------|------------|------------|------------|------------|--|
| Axis | | 3 Axis | 3 Axis | 4 Axis | 4 Axis | |
| stroke(mm) | X1 axis | 300 | 400 | 300 | 400 | |
| | X2 axis (R axis) | -(320°) | -(320°) | 300 | 400 | |
| | Y axis | 300 | 400 | 500 | 600 | |
| | Z axis | 100 | 100 | 100 | 100 | |
| servo motor(W) | X1 axis | 100 | 100 | 100 | 100 | |
| | X2 axis (R axis) | -(100) | -(100) | 100 | 100 | |
| | Y axis | 100 | 100 | 200 | 200 | |
| | Z axis | 100(Brake) | 100(Brake) | 100(Brake) | 100(Brake) | |
| MAX.Load(kg) | X1 axis | 24kg | 24kg | 24kg | 24kg | |
| | X2 axis (R axis) | -(3kg) | -(3kg) | 24kg | 24kg | |
| | Y axis | 24kg | 24kg | 24kg | 24kg | |
| | Z axis | 7kg | 7kg | 7kg | 7kg | |
| MAX.speed | X1 axis | 500mm/sec | 500mm/sec | 500mm/sec | 500mm/sec | |
| | X2 axis (R axis) | -(360°/s) | -(360°/s) | 500mm/sec | 500mm/sec | |
| | Y axis | 500mm/sec | 500mm/sec | 500mm/sec | 500mm/sec | |
| | Z axis | 500mm/sec | 500mm/sec | 500mm/sec | 500mm/sec | |
| Repeatability | ± 0.02mm | | ± 0.02mm | | ± 0.02mm | |
| controller | inside | | inside | | inside | |

ECORO DESKTOP ROBOT ②

| Model | | 221 | 331 | 441 | 3351 | |
|---------------|------------------|-----------|------------|------------|-----------|--|
| Axis | | 3 Axis | 3 Axis | 3 Axis | 4 Axis | |
| stroke(mm) | X1 axis | 200 | 300 | 400 | 300 | |
| | X2 axis (R axis) | - (-) | -(320°) | -(320°) | 300 | |
| | Y axis | 200 | 300 | 400 | 500 | |
| | Z axis | 50 | 100 | 100 | 100 | |
| step motor | X1 axis | 56 *42mm | 56 *76mm | 56 *76mm | 56 *76mm | |
| | X2 axis (R axis) | - (-) | -(56*76mm) | -(56*76mm) | 56 *76mm | |
| | Y axis | 56 *76mm | 56 *76mm | 56 *76mm | 56 *76mm | |
| | Z axis | 56 *76mm | 56 *76mm | 56 *76mm | 56 *76mm | |
| MAX.Load(kg) | X1 axis | 10kg | 10kg | 10kg | 10kg | |
| | X2 axis (R axis) | - | -(3kg) | -(3kg) | 10kg | |
| | Y axis | 15kg | 15kg | 15kg | 15kg | |
| | Z axis | 5kg | 5kg | 5kg | 5kg | |
| MAX.speed | X1 axis | 450mm/sec | 450mm/sec | 450mm/sec | 450mm/sec | |
| | X2 axis (R axis) | - (-) | -(360°/s) | -(360°/s) | 450mm/sec | |
| | Y axis | 450mm/sec | 450mm/sec | 450mm/sec | 450mm/sec | |
| | Z axis | 100mm/sec | 200mm/sec | 200mm/sec | 200mm/sec | |
| Repeatability | ± 0.1mm | | ± 0.1mm | | ± 0.1mm | |
| controller | inside | | inside | | inside | |

ROBOTS

ANY CARTESIAN

Any Cartesian Series

Any cartesian series is a robot dispensing system that is excellent for dispensing applications that require mass production of large-sized products at high speed. It is a customized solution for customer applications that can be selected in combination with various forms in response to various processes. The combination of AC servomotor, ball screw, and LM guide enables high-speed and high-accuracy work. It provides product specifications of Repeatability ± 0.02 and payload of min 21kg~max 100kg.



Robot Multi Head Tool

A multi head tool applied to the robot dispenser. The Barrel, Valve, and Tube can be mounted to the tool, and various types can be selected from one array according to the working process.

| MHB | 3 | 5A | 30 |
|--|------------------------------|---------------|--|
| Micro Holder B: Barrel V: Valve T: Yube | 3axis adjuster For manual | Count of Head | Model No. of barrel Model No. of valve Model No. of tube |



Micro Holder

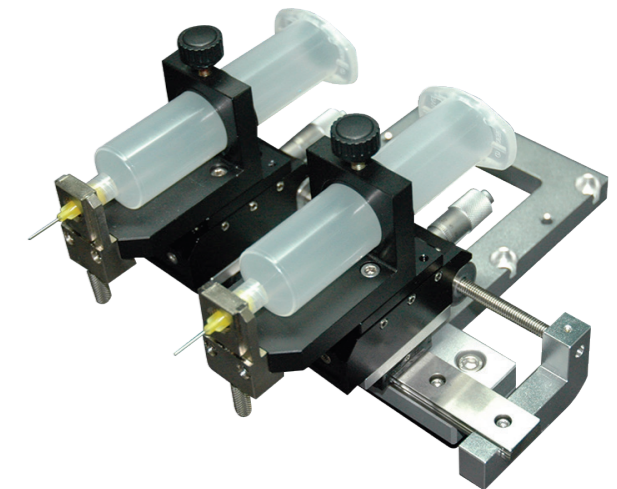

MHB-3-2A-30

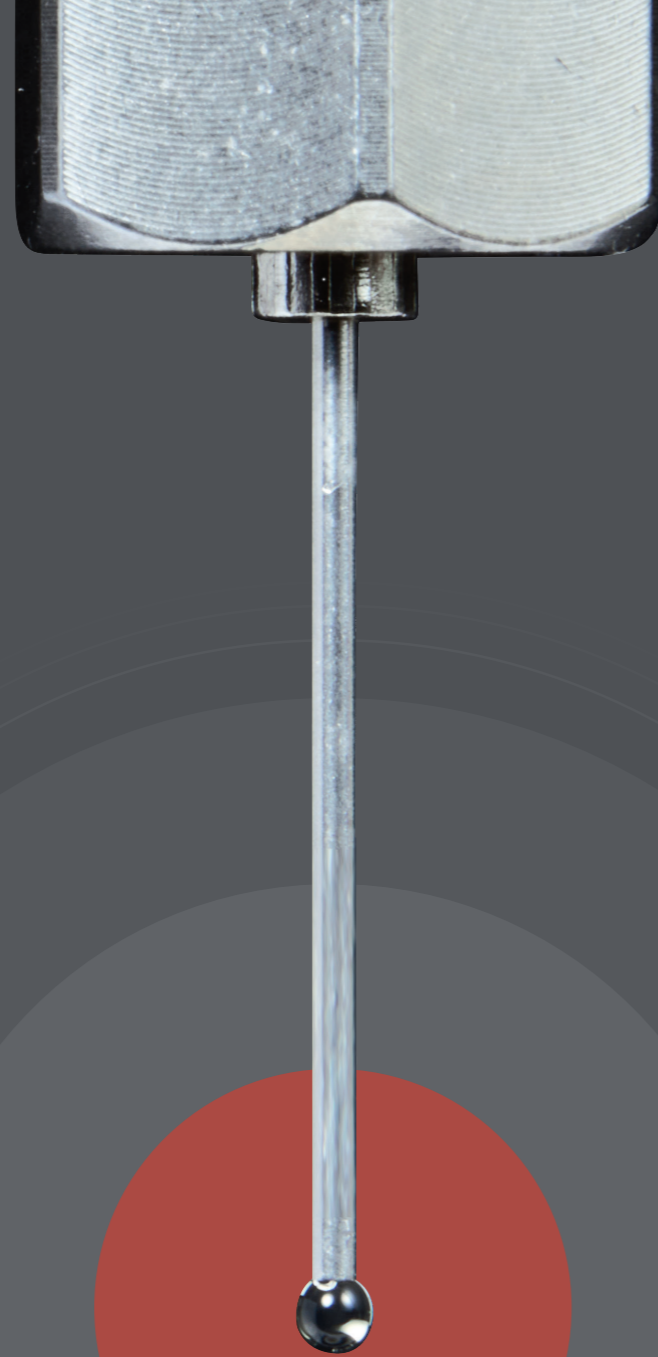

FIRST ONE

This is the first introduction to the world, Banseok developed the Metal Coated Needle on which the fluid don't rise to the needle, therefore provides the optimal dispensing solution.

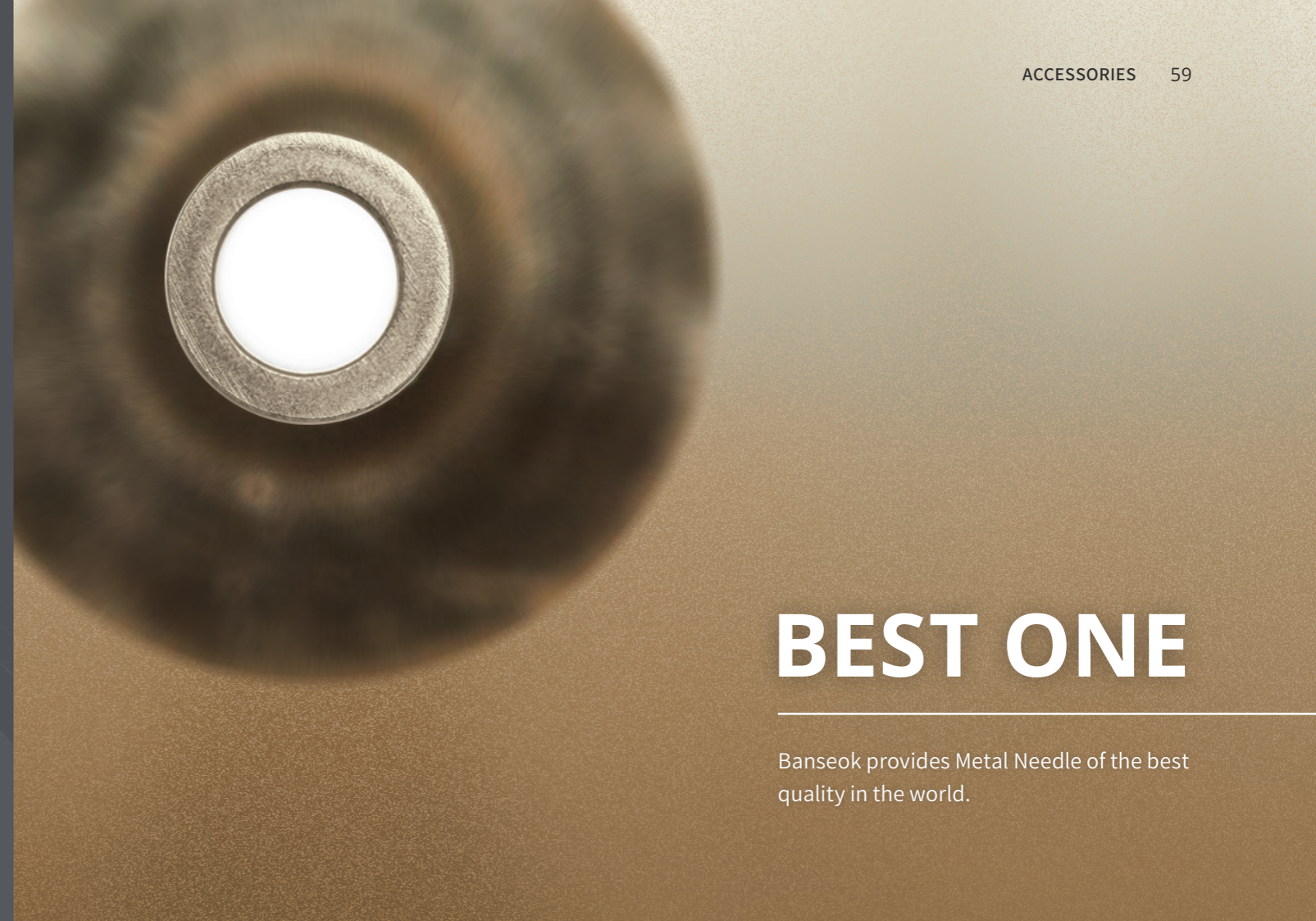

BEST ONE

Banseok provides Metal Needle of the best quality in the world.

ONLY ONE

Banseok provides the only Metal Needle customizing service in the world, providing Metal Needle with the desired shape, function, specifications. Design your own Metal Needle with Banseok.



ACCESSORIES

Metal Coated Needle Manufacturing Technology of Banseok Precision has been completed over the years. Banseok has the technology of self-developed precision assembling equipment, pipe machining, Hub machining, and needle coating which are the world's best quality. The metal needle in dispensing is a basic component used in every application, Banseok has achieved the best precision and quality in the world.

PRECISION METAL NEEDLE

Banseok has developed the world's first trial of Metal needle with the same out diameter with wider in diameter, which enables to improve the dispensing speed and less dripping with high viscosity fluid.



METAL COATED NEEDLE

In order to reduce the inconvenience of cleaning the needle each time after dispensing and the error caused by the needle contamination, Banseok offers the specialized coating option to eliminate the fluid rising on the needle. If the low-viscosity micro dispensing applications failed with previous standard needles from other companies, it is possible to use Banseok's special metal-coated needle.

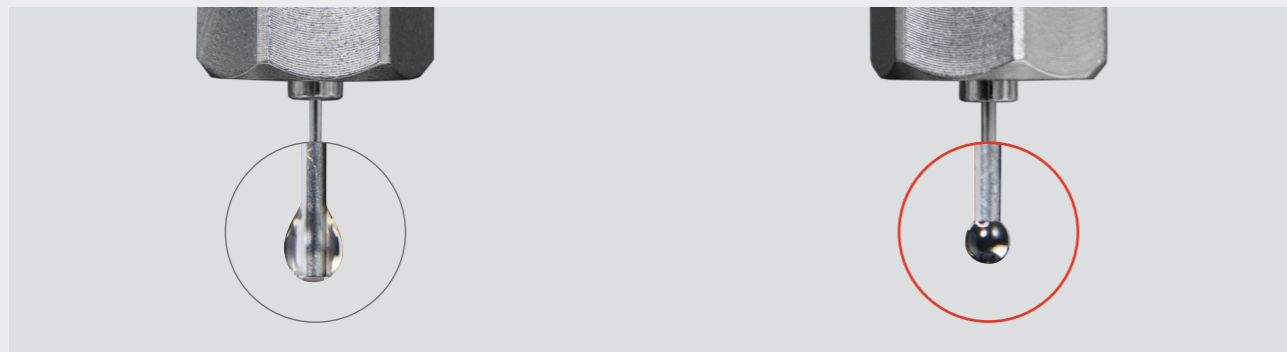

Normal Needle

The fluid material climbs up the needle, causing the contamination on the pipe. This contamination can be discussed when dispensing equal amount.

Metal Coated Needle

A special coated needle eliminated the climbing of the fluid, making the equal quality of dispensing.

Standard type

The highest quality in the world. Standard needle of 13mm long, and order-made lengths are available.

Precision type

It's the world's first attempt and technology. Its outer diameter is same as the standard needle but has a bigger inner diameter. The Drip Free metal needle has the same internal diameter and external diameter as the precision nozzle. If using the high viscosity fluid, the dispensing speed goes significantly slow. Using a drip free metal needle with a bigger inner diameter, you will get a ideal dispensing speed. The needle length is an order-made.



MN-19G



MN-19G-TW



| Model | In Dia. | Out Dia. |
|--------|---------|----------|
| MN-12G | 2.4 | 2.76 |
| MN-13G | 1.9 | 2.41 |
| MN-14G | 1.64 | 2.1 |
| MN-15G | 1.43 | 1.8 |
| MN-16G | 1.2 | 1.65 |
| MN-17G | 1.12 | 1.48 |
| MN-18G | 0.84 | 1.27 |
| MN-19G | 0.69 | 1.07 |
| MN-20G | 0.6 | 0.91 |
| MN-21G | 0.51 | 0.815 |
| MN-22G | 0.41 | 0.71 |
| MN-23G | 0.33 | 0.635 |
| MN-24G | 0.31 | 0.55 |
| MN-25G | 0.25 | 0.51 |
| MN-26G | 0.23 | 0.45 |
| MN-27G | 0.2 | 0.4 |
| MN-28G | 0.18 | 0.35 |
| MN-29G | 0.17 | 0.33 |
| MN-30G | 0.15 | 0.3 |
| MN-31G | 0.13 | 0.26 |
| MN-32G | 0.1 | 0.23 |

| Model | In Dia. | Out Dia. |
|-----------|---------|----------|
| MN-14G-TW | 1.8 | 2.1 |
| MN-15G-TW | 1.54 | 1.8 |
| MN-16G-TW | 1.37 | 1.65 |
| MN-17G-TW | 1.22 | 1.48 |
| MN-18G-TW | 1.03 | 1.27 |
| MN-19G-TW | 0.84 | 1.07 |
| MN-20G-TW | 0.68 | 0.91 |
| MN-21G-TW | 0.59 | 0.815 |
| MN-22G-TW | 0.5 | 0.71 |
| MN-23G-TW | 0.43 | 0.635 |
| MN-24G-TW | 0.36 | 0.55 |
| MN-25G-TW | 0.33 | 0.51 |
| MN-26G-TW | 0.31 | 0.45 |
| MN-27G-TW | 0.29 | 0.4 |
| MN-28G-TW | 0.25 | 0.35 |
| MN-29G-TW | 0.21 | 0.33 |
| MN-30G-TW | 0.2 | 0.3 |
| MN-31G-TW | 0.16 | 0.26 |
| MN-32G-TW | 0.14 | 0.23 |

ACCESSORIES

PLASTIC NEEDLE

The plastic needle is used to dispense the fluid in general.

Needle L = 13mm, 25mm



| Model | In Dia | Out Dia | Color |
|---------|--------|---------|-------------|
| BPN-14G | 1.75 | 2.08 | Green |
| BPN-15G | 1.49 | 1.81 | Orange |
| BPN-16G | 1.33 | 1.63 | Purple |
| BPN-17G | 1.15 | 1.46 | White |
| BPN-18G | 0.97 | 1.25 | Pink |
| BPN-19G | 0.77 | 1.04 | Brown |
| BPN-20G | 0.62 | 0.9 | Yellow |
| BPN-21G | 0.54 | 0.81 | Light Green |
| BPN-22G | 0.44 | 0.71 | Black |
| BPN-23G | 0.39 | 0.63 | Light Blue |
| BPN-24G | 0.31 | 0.55 | Red |
| BPN-25G | 0.28 | 0.5 | Blue |
| BPN-26G | 0.24 | 0.45 | Beige |
| BPN-27G | 0.2 | 0.4 | Gray |
| BPN-30G | 0.12 | 0.3 | Lavender |

TAPER NEEDLE

The needle useful for dispensing of high viscosity fluids, without damaging on the products.



| Model | In Dia. | Color |
|---------|---------|-----------|
| BTN-14G | 1.61 | Salmon |
| BTN-16G | 1.22 | Gray |
| BTN-18G | 0.89 | Green |
| BTN-20G | 0.62 | Pink |
| BTN-22G | 0.43 | Blue |
| BTN-24G | 0.30 | Dark pink |

ANGLED NEEDLE

The needle is bent by 45° and is used when dispense is interrupted by the products.



| Model | In Dia | Out Dia | Color |
|---------|--------|---------|----------|
| BAN-18G | 0.84 | 1.27 | Green |
| BAN-20G | 0.6 | 1.91 | Pink |
| BAN-21G | 0.51 | 1.82 | Lavender |
| BAN-22G | 0.41 | 1.72 | Blue |
| BAN-23G | 0.34 | 1.64 | Orange |
| BAN-25G | 0.26 | 0.51 | Red |
| BAN-27G | 0.21 | 0.41 | White |

TEFLON NEEDLE

The needle of Teflon materials with chemical resistance and flexibility.

Needle L = 13mm, P = 40mm



| Model | Color |
|----------|-------------|
| BTFN-14G | Green |
| BTFN-15G | Orange |
| BTFN-21G | Light Green |
| BTFN-22G | Black |
| BTFN-23G | Light Blue |
| BTFN-26G | Beige |
| BTFN-30G | Lavender |

TEFLON NEEDLE WITH SUS GUIDE

The needle for precise dispensing with chemical resistance. The SUS guide prevents the wavering of the needles.



| Model | Teflon | SUS | Color |
|--------|--------|------|-------|
| TN-25G | 0.3 | 1.27 | Pink |
| TN-27G | 0.2 | 0.9 | Red |



ACCESSORIES

POLYPROPYLENE NEEDLE

The needle with chemical resistance and flexible polypropylene tubing.

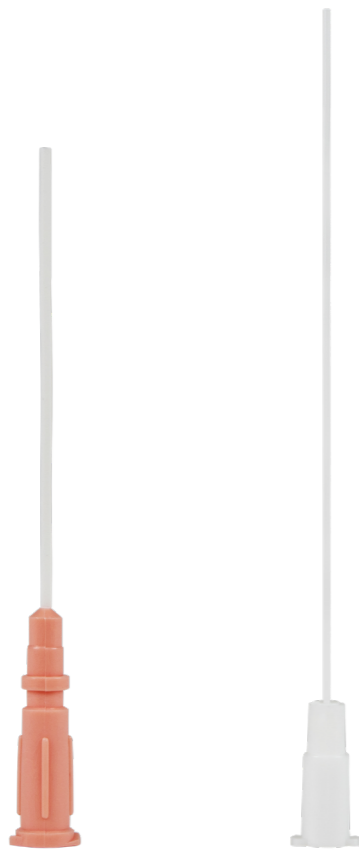

| Model | Teflon | SUS | Color |
|---------|--------|------|--------|
| BFN-20G | 0.58 | 0.91 | Orange |
| BFN-22G | 0.41 | 0.71 | White |

BRUSH NEEDLE

Useful when brushing applications of grease or materials which is not hardened.



| Model | Tip Spec |
|--------|----------|
| BRN-F | Soft |
| BRN-BB | Midium |
| BRN-H | Hard |

MIXER PART

If there is a large difference in the mixing ratio between resin and hardener, the static mixer may not perform properly. In this case, the power mixer using the servo motor can mechanically mix the 2K fluid materials.

| Mixer element | Description |
|---------------|------------------|
| SME-16.4/10 | Ø16.4 × 10 step |
| SME-16/10 | Ø16 × 10 step |
| SME-12.65/12 | Ø12.65 × 12 step |
| SME-9.4/12 | Ø9.4 × 12 step |
| SME-6.4/16 | Ø6.4 × 16 step |

| Static mixer | Description |
|--------------|------------------|
| SM-12.65/36 | Ø12.65 × 36 step |
| SM-12.65/30 | Ø12.65 × 30 step |
| SM-12.65/24 | Ø12.65 × 24 step |
| SM-12.65/12 | Ø12.65 × 12 step |
| SM-9.4/30 | Ø9.4 × 30 step |
| SM-9.4/24 | Ø9.4 × 24 step |
| SM-6.4/16 | Ø6.4 × 16 step |
| SM-5.4/7 | Ø5.4 × 7 step |
| SM-3/7 | Ø3 × 7 step |



Mixers

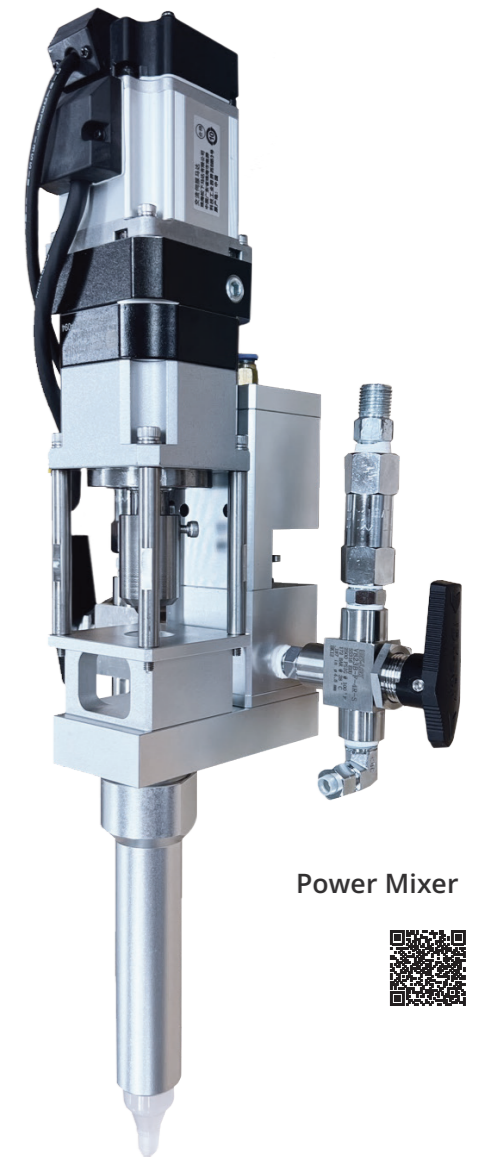

Power Mixer



ACCESSORIES

PRECISION NOZZLE

The nozzle used for precise dispensing of high viscosity fluids.



| Model | In Dia |
|---------|--------|
| PN-0.3S | 0.3 |
| PN-0.4S | 0.4 |
| PN-0.5S | 0.5 |
| PN-0.6S | 0.6 |
| PN-0.7S | 0.7 |
| PN-0.8S | 0.8 |
| PN-0.9S | 0.9 |
| PN-1.0S | 1 |
| PN-1.1S | 1.1 |
| PN-1.2S | 1.2 |

HIGH QUALITY PRECISION NOZZLE

This is the high quality model of precision nozzle.



Teflon Precision Nozzle

A teflon material precision nozzle for the anaerobic fluid application.



| Model | In Dia |
|----------|--------|
| PN-0.2A | 0.2 |
| PN-0.25A | 0.25 |
| PN-0.3A | 0.3 |
| PN-0.4A | 0.4 |
| PN-0.5A | 0.5 |



Precision Nozzle-Luer Lock Type

A precision nozzle designed to be mounted directly to the luer lock type valve.



Precision Nozzle-Ruby Type

A Precision nozzle which are made with Ruby to tolerate the highly frictional fluid materials while maintaining high thermal conductivity.



TWIN METAL NEEDLE

The needle designed for 2 points of simultaneous dispensing.

Needle L = 20mm, P = 2.5mm



| Model | In Dia | Out Dia |
|---------|--------|---------|
| BDN-17G | 1.12 | 1.48 |
| BDN-18G | 0.84 | 1.27 |
| BDN-19G | 0.64 | 1.07 |
| BDN-20G | 0.69 | 0.91 |
| BDN-21G | 0.60 | 0.82 |
| BDN-22G | 0.51 | 0.71 |
| BDN-23G | 0.41 | 0.64 |
| BDN-24G | 0.33 | 0.55 |
| BDN-25G | 0.25 | 0.51 |
| BDN-26G | 0.23 | 0.45 |

Multi Metal Needle

The needle used when applying multi points. An order-made product according to user's application

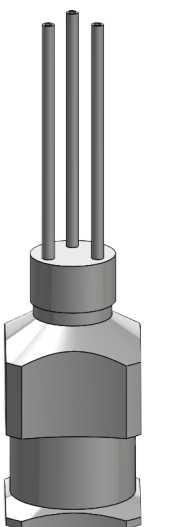

ACCESSORIES

BARREL

This highly precise barrels for dispensing are designed to stand high pressure considering the fluid's flow property. The barrel is designed to dispense high viscosity fluid with no remains. The shape and the material are considered for the safety.



CARTRIDGE

Larger volume of fluid material than barrel can be used with cartridge. Or the fluid material provided in cartridge can be used directly in cartridge holder. The standard specification is 170 / 340 / 600 / 950cc.



| | Cartridge | Holder | Plunger | Cap |
|-------|-----------|--------|---------|--------|
| 170cc | CR-170 | CH-170 | CP-170 | CC-170 |
| 340cc | CR-340 | CH-340 | CP-340 | CC-340 |
| 600cc | CR-600 | CH-600 | CP-600 | CC-600 |
| 950cc | CR-950 | CH-950 | CP-950 | CC-950 |

BARREL ACCESSORIES

PISTON

The piston plunges material filled in the barrel with no remains. Three kinds regarding the viscosity are available. High viscosity (H; Light blue), Low viscosity (L: white), Air-contact prevention (R: Rubber).



TIP CAP

Tip cap is used to close the bottom of all kinds of the barrel.



HAND SWITCH (BS-H3)

The convenient hand switch attached to the barrel can be operated manually.



BARREL STAND (BS-101)



PENCIL SWITCH (MN-7)

For BX-2



TOP CAP

Top cap is used to close the top of the barrel when storing fluids after use.



O-RING

O-Ring is used for sealing the barrel and adapter.



FOOT SWITCH

The convenient foot switch attached to the controller can be operated manually.



PICK UP PEN (MN-5)

For TAD-200SP



NOZZLE FOR MN-7 (MN-7N-00G)

For BX-2



ACCESSORIES

REGULATOR SET

Air regulator

Air regulator sets and displays the air pressure that is supplied to containers.

BR-10K (S:0~10kg/cm², Standard)

BR-04K (L:0~4kg/cm², Low pressure)



Filter regulator

Filter regulator cleans the air and supplies to the dispenser.



TEFLON TUBE(UV) / SILICONE TUBE

For tubing dispenser(BX-2).



Teflon Tube(UV)



Silicone Tube

| AWG | In×Out Dia | Type | AWG | In×Out Dia | Type |
|--------|------------|------|---------------|------------|------|
| TT-30G | 0.3 × 0.6 | M | TT-11G | 2.4 × 3.0 | T |
| TT-26G | 0.5 × 1.0 | S | TT-10G | 2.7 × 3.3 | T |
| TT-24G | 0.6 × 1.1 | S | TT-9G | 3.0 × 3.6 | T |
| TT-22G | 0.7 × 1.2 | S | TT-8G | 3.3 × 3.9 | T |
| TT-20G | 0.9 × 1.5 | T | TT-7G | 3.8 × 4.4 | T |
| TT-19G | 1.0 × 1.6 | T | Silicone tube | 0.5 × 2.5 | G |
| TT-18G | 1.1 × 1.7 | T | Silicone tube | 3.0 × 5.0 | G |
| TT-17G | 1.2 × 1.8 | T | Silicone tube | 8.0 × 10 | G |
| TT-16G | 1.4 × 2.0 | T | TT-24B (UV) | 0.6 × 1.0 | S |
| TT-15G | 1.6 × 2.2 | T | TT-19B (UV) | 1.0 × 1.6 | T |
| TT-14G | 1.7 × 2.3 | T | TT-16B (UV) | 1.4 × 2.0 | T |
| TT-13G | 1.9 × 2.5 | T | TT-13B (UV) | 1.9 × 2.5 | T |
| TT-12G | 2.2 × 2.8 | T | | | |

APPLICATION

IN-LINE AUTOMATION SYSTEM



5AXIS ROBOT DISPENSING SYSTEM



APPLICATION

TWO LIQUID TYPE DISPENSING SYSTEM

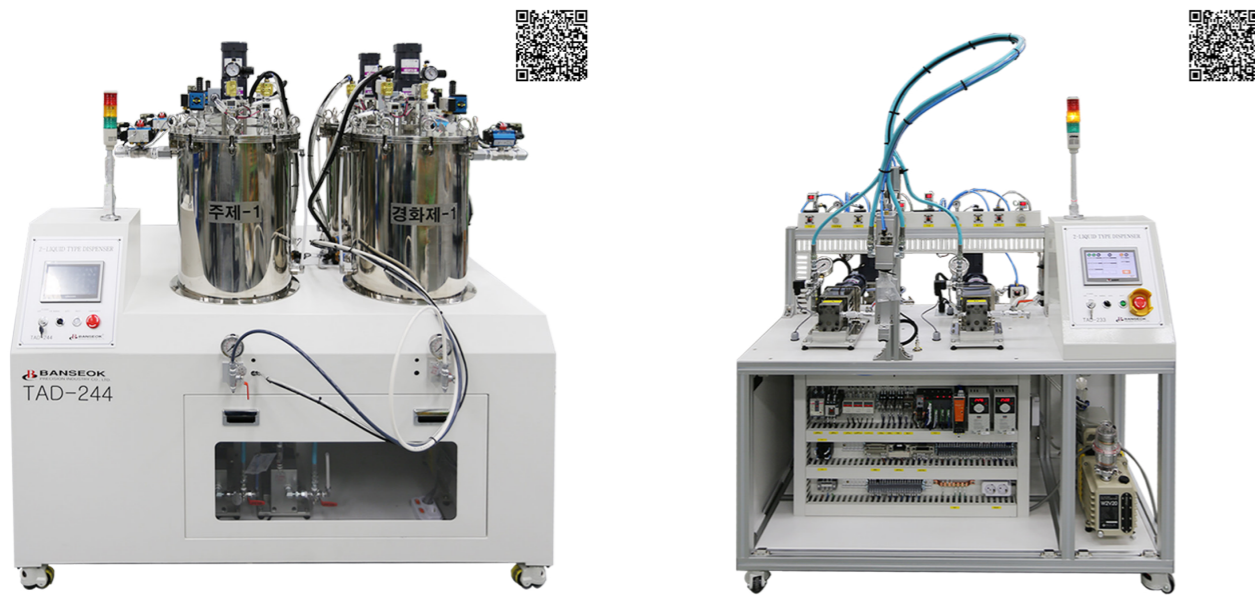

CONFORMAL COATING SYSTEM



HEAD OFFICE/R&D LAB

B101~B104, FORHU, 58, Wangshimni-ro, Seongdong-gu, Seoul, Republic of Korea
TEL. +82-2-469-1239 FAX. +82-2-469-6955

DAEGU BRANCH

305, 3rd Floor, 46, Igokseo-ro, Dalseo-gu, Daegu, Republic of Korea
TEL. +82-10-9263-5910

SHENZHEN BRANCH, CHINA

Room 1306, Mingjun Business Center, No.1 Langrong Road, Dalang Street,
Longhua District, Shenzhen, Guangdong, China
TEL. +86-755-8204-6882 FAX. +86-755-8204-4378

WEBSITE

www.banseok.co.kr

CONTACT

trade@banseok.co.kr(Oversea dept.)

